

Power Supply Supervisor

Features

- Low power consumption
- Low temperature coefficient
- Built-in delay circuit: 200ms
- High input voltage (up to 8V)
- Output voltage accuracy: tolerance $\pm 2\%$
- SOT23 ,SOT23-3 and SOT89 package

Applications

- Microprocessor reset circuitry
- Memory battery back-up circuits
- Power on reset circuits
- System battery life and charge voltage monitors
- Delay circuitry
- Power failure detection

General Description

The TP809 series are highly accurate, low power consumption voltage detectors, manufactured using CMOS and laser trimming technologies. A delay circuit is built-in to each detectors. Detect voltage is extremely accurate with minimal temperature drift. Both CMOS and N-ch open drain output configurations are available. Since the delay circuit is built-in, peripherals are unnecessary and high density mounting is possible.

Selection Table

Part No	Detectable Voltage	Delay Time	Tolerance	Package
TP809Y-xxxXX	3.08V	200ms	$\pm 2\%$	SOT23
	2.93V		$\pm 2\%$	SOT23-3
	2.63V		$\pm 2\%$	SOT89

Note: "Y" is CMOS or NMOS output. "xxx" stands for detectable voltages. "XX" stands for package.

Order Information

TP809①-②③④⑤⑥

Designator	Symbol	Description
①	C	CMOS output
	N	NMOS output
②③④	xxx	Detect voltage
⑤	X	Package:SOT23
	M	Package:SOT23-3
	P	Package:SOT89
⑥	R	RoHS / Pb Free
	G	Halogen Free

Block Diagram

(1) CMOS output

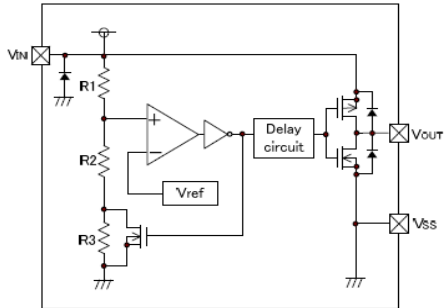

(2) N-ch open drain output

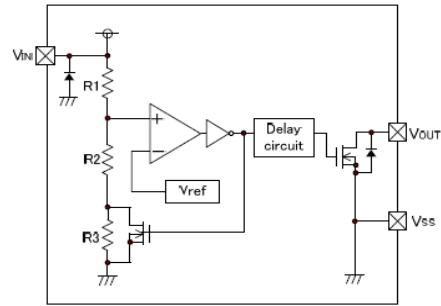

Marking Rule

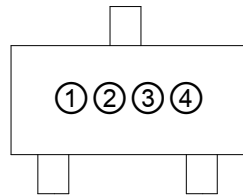

SOT23/SOT23-3(TOP VIEW)

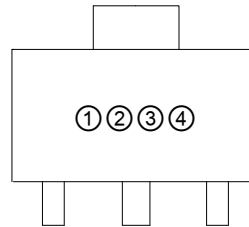

SOT89 (TOP VIEW)

Product	Mark	Product	Mark
TP809C-263	AFAA	TP809N-263	BFAA
TP809C-293	ADAA	TP809N-293	BDAA
TP809C-308	ACAA	TP809N-308	BCAA

Product Information

Product	Package	MPQ
TP809C/TP809N	SOT23	3000PCS
	SOT23-3	3000PCS
	SOT89	1000PCS

Pin Assignment

SOT23/SOT23-3(TOP VIEW)

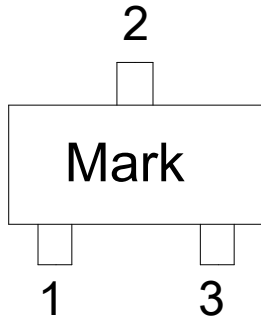

Table1 TP809C/TP809N series (SOT23/SOT23-3 PKG)

PIN NO.	PIN NAME	FUNCTION
1	GND	GND pin
2	VIN	Input voltage pin
3	Reset	Reset pin

SOT89 (TOP VIEW)

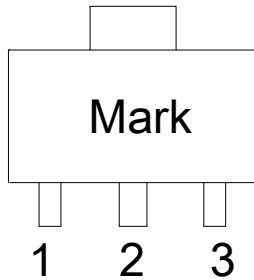

Table2 TP809C/TP809N series (SOT89 PKG)

PIN NO.	PIN NAME	FUNCTION
1	GND	GND pin
2	VIN	Input voltage pin
3	Reset	Reset pin

Absolute Maximum Ratings

Input Voltage-0.3V to 8.0V

Storage Temperature-40°C to 125°C

Operating Temperature-30°C to 80°C

Note: These are stress ratings only. Stresses exceeding the range specified under “Absolute Maximum Ratings” may cause substantial damage to the device. Functional operation of this device at other conditions beyond those listed in the specification is not implied and prolonged exposure to extreme conditions may affect device reliability.

Thermal Information

Symbol	Parameter	Package	Max.	Unit
θ_{JA}	Thermal Resistance (Junction to Ambient) (Assume no ambient airflow, no heat sink)	SOT23-3	250	°C/W
		SOT89	500	°C/W
P_D	Power Dissipation	SOT23-3	0.20	W
		SOT89	0.50	W

Note: P_D is measured at $T_a = 25^\circ\text{C}$

Electrical Characteristics

Symbol	Parameter	Test Conditions	Min.	Typ.	Max.	Unit
V _{CC}	Input Voltage (V _{CC}) Range	25°C	1.2		7.5	V
I _{SS}	Supply Current	V _{IN} =6V, V _{det} =2.63V	1	1.8	2.5	μA
V _{DET}	Reset Threshold	TA=25°C	3.04	3.08	3.11	V
		TA=25°C	2.89	2.93	2.96	
		TA=25°C	2.59	2.63	2.66	
	Reset Threshold Stability			30		Ppm/ °C
	V _{CC} to Reset Delay	V _{CC} = V _{TH} to V _{TH} -100mV		20		us
V _{OL}	Reset Active Timeout Period		100	200	300	ms

Timing Chart

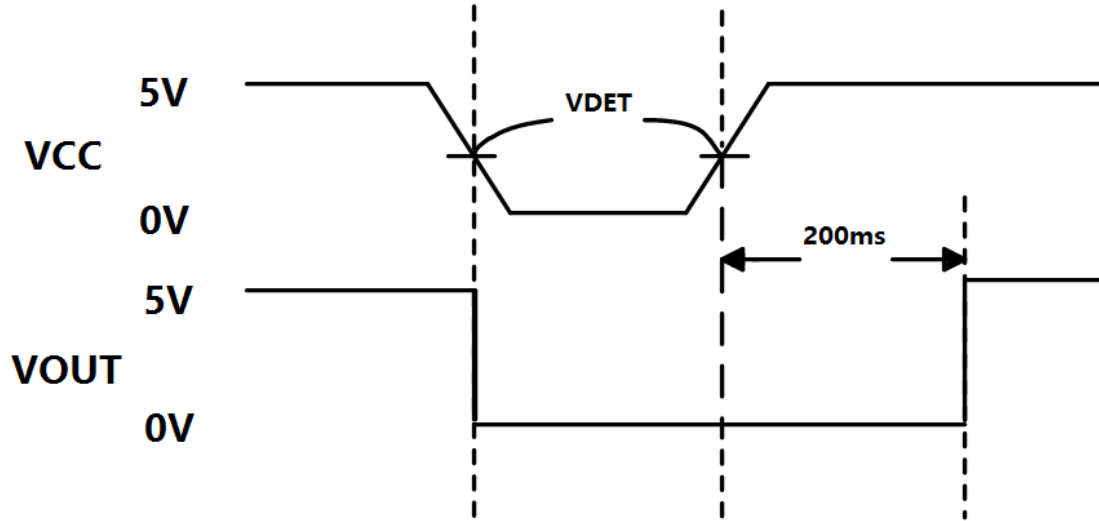

Application Circuits

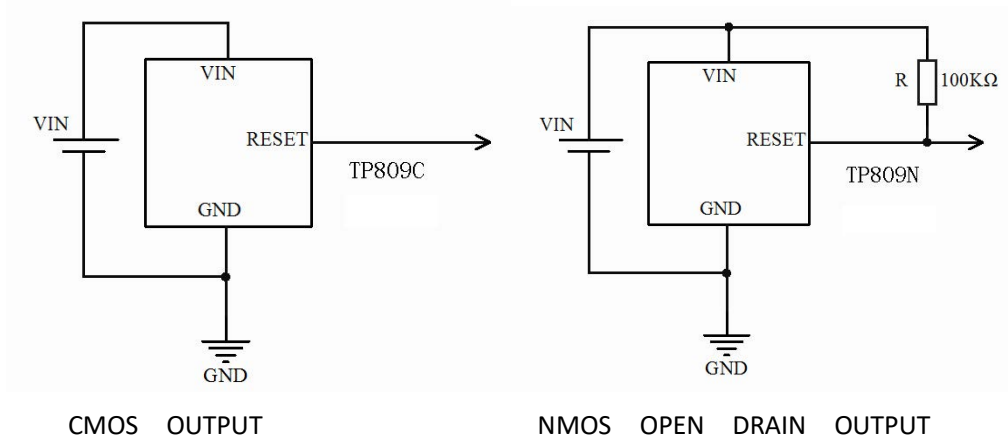

Package Information
3-pin SOT23 Outline Dimensions

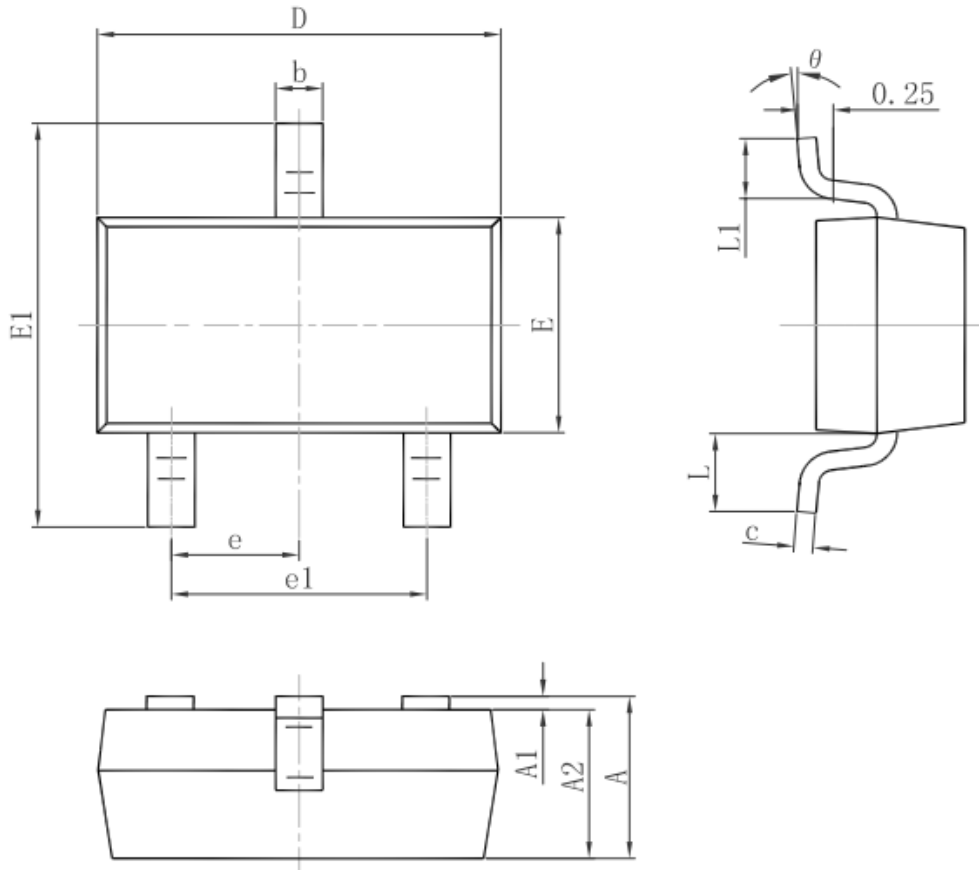

Symbol	Dimensions In Millimeters		Dimensions In Inches	
	Min.	Max.	Min.	Max.
A	0.900	1.150	0.035	0.045
A1	0.000	0.100	0.000	0.004
A2	0.900	1.050	0.035	0.041
b	0.300	0.500	0.012	0.020
c	0.080	0.150	0.003	0.006
D	2.800	3.000	0.110	0.118
E	1.200	1.400	0.047	0.055
E1	2.250	2.550	0.089	0.100
e	0.950 TYP.		0.037 TYP.	
e1	1.800	2.000	0.071	0.079
L	0.550 REF.		0.022 REF.	
L1	0.300	0.500	0.012	0.020
theta	0°	8°	0°	8°

3-pin SOT89 Outline Dimensions

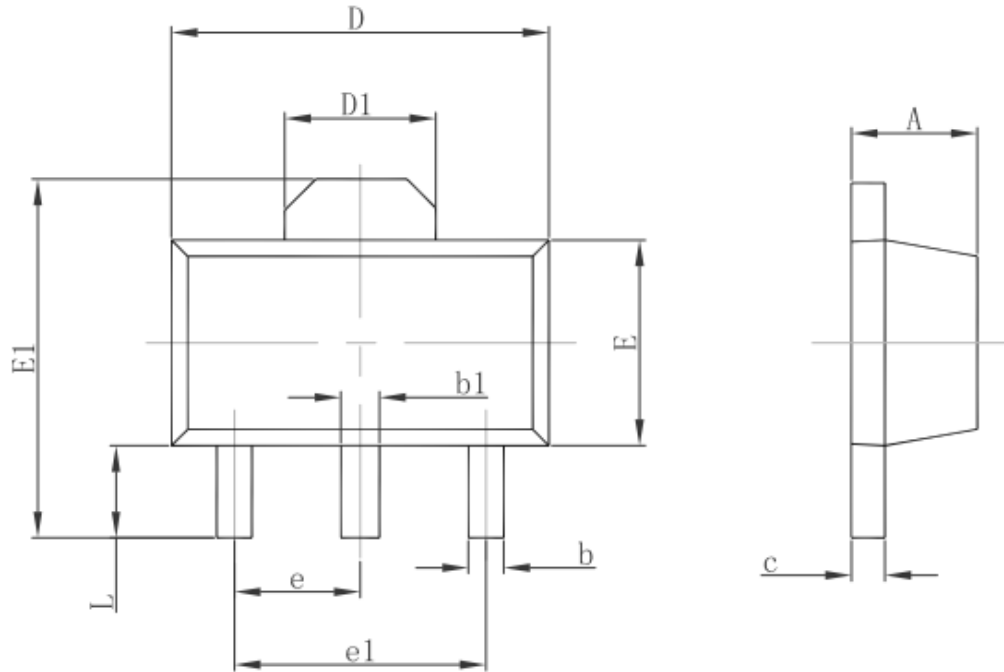

Symbol	Dimensions In Millimeters		Dimensions In Inches	
	Min.	Max.	Min.	Max.
A	1.400	1.600	0.055	0.063
b	0.320	0.520	0.013	0.020
b1	0.400	0.580	0.016	0.023
c	0.350	0.440	0.014	0.017
D	4.400	4.600	0.173	0.181
D1	1.550 REF.		0.061 REF.	
E	2.300	2.600	0.091	0.102
E1	3.940	4.250	0.155	0.167
e	1.500 TYP.		0.060 TYP.	
e1	3.000 TYP.		0.118 TYP.	
L	0.900	1.200	0.035	0.047

3-pin SOT23-3 Outline Dimensions

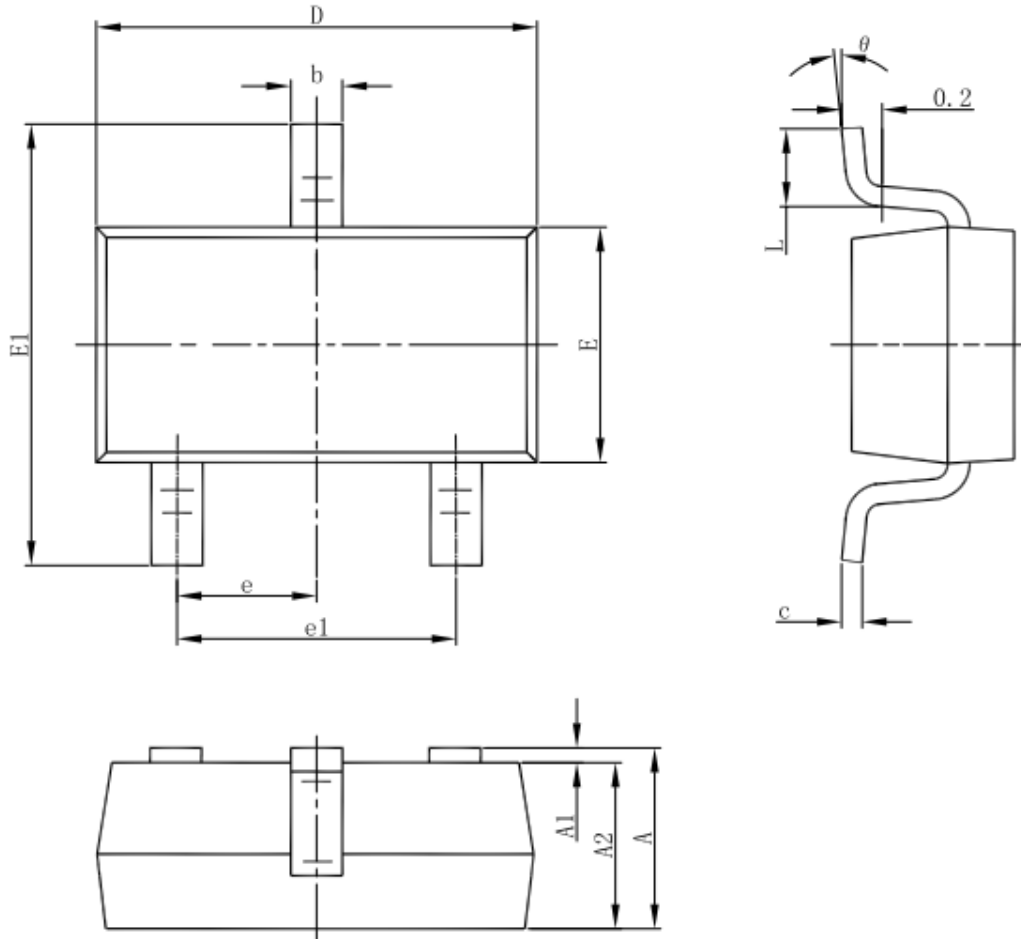

Symbol	Dimensions In Millimeters		Dimensions In Inches	
	Min	Max	Min	Max
A	1.050	1.250	0.041	0.049
A1	0.000	0.100	0.000	0.004
A2	1.050	1.150	0.041	0.045
b	0.300	0.500	0.012	0.020
c	0.100	0.200	0.004	0.008
D	2.820	3.020	0.111	0.119
E	1.500	1.700	0.059	0.067
E1	2.650	2.950	0.104	0.116
e	0.950(BSC)		0.037(BSC)	
e1	1.800	2.000	0.071	0.079
L	0.300	0.600	0.012	0.024
θ	0°	8°	0°	8°